

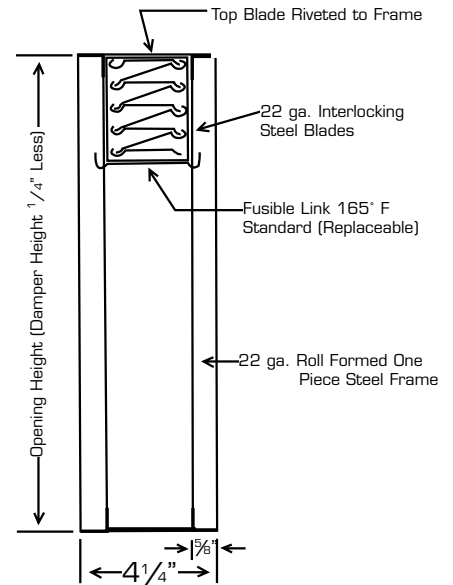

**CERTIFICATION & SUBMITTAL**  
**MODEL 5500 FIRE-TITE™ UL FIRE DAMPERS**  
**"A" Frames**  
**FOR USE IN STATIC SYSTEMS ONLY**

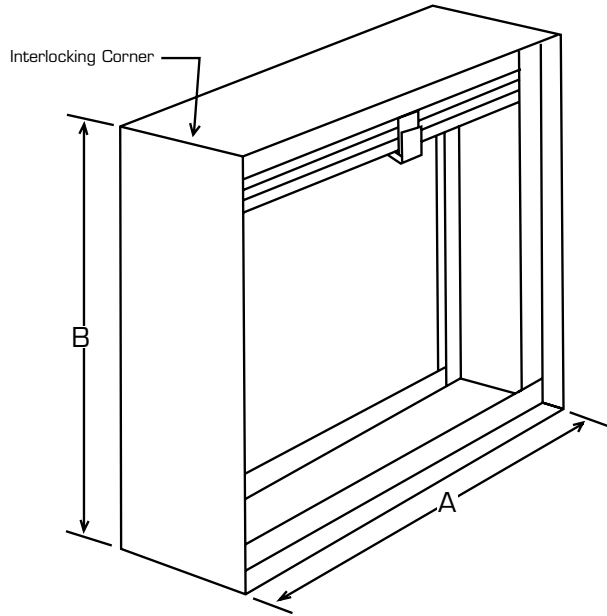

**VERTICAL MOUNT  
 MODEL 5510**

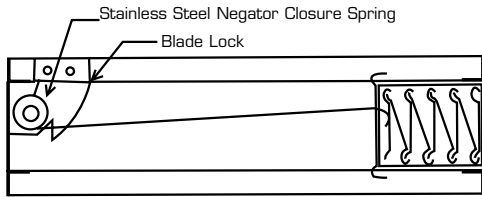

**HORIZONTAL MOUNT  
 MODEL 5511**

UNDERWRITERS LABORATORIES, INC.™ CLASSIFIED FIRE DAMPER No. <input type="text"/> FIRE RESISTANCE RATING 1-1/2 HOUR	<b>VENT          PRODUCTS          CO., INC.</b>
---	--

California Fire Marshal  
 Listing No. 3225-1078:100

**ALL DAMPERS 1/4" UNDER LISTED DIMENSIONS**

**MINIMUM SIZE:** 4" x 4"

**MAXIMUM DUCT OPENING  
 SINGLE SECTION:**

**VERTICAL:** 60" x 60"  
**HORIZONTAL:** 60" x 60"

**MAXIMUM MULTIPLE SECTION**

**VERTICAL:** 120" x 120"  
**HORIZONTAL:** 102" x 60"

**MATERIALS:** Standard construction - galvanized steel. Specifications for all material per Underwriters Laboratories Standard for Safety UL 555.

**UNDERWRITERS LABORATORIES:** Labeled for use in sizes no larger than shown in UL Building Materials List in a 2-hour fire partition.

Meets N.F.P.A. 90A Requirements.

Refer to Form 5505 for installation instructions.

Optional 304 Stainless Steel Construction available.

Optional 212°F Fusible Link available.