

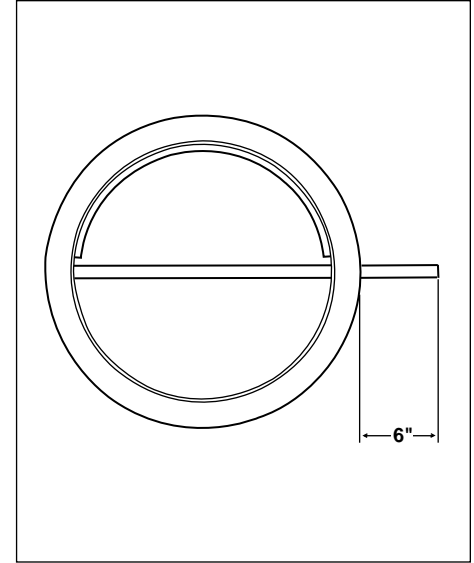

**CERTIFICATION & SUBMITTAL  
 MODEL 5311  
 Medium Duty Round Dampers**

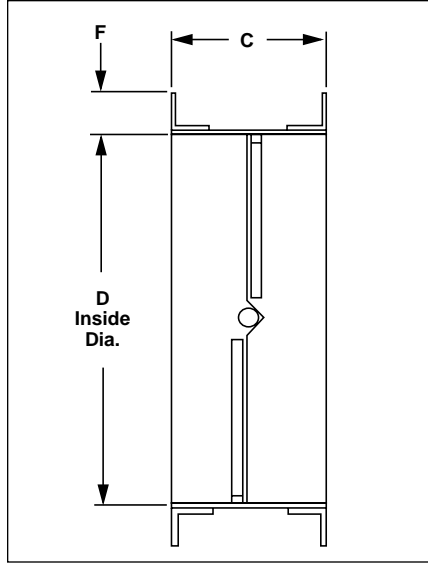
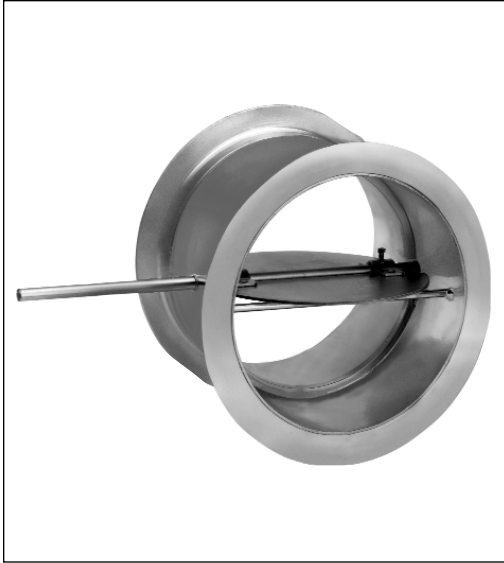

**STANDARD SPECIFICATIONS**

- **FRAME:** Rolled galvanized steel.  
(See table for specifications.)
- **BLADES:** 11 ga. galv. press formed steel.  
Stiffened as required.
- **AXLES:** 1/2" dia. full-length C1018 plated steel rod.
- **BEARINGS:** 1/2" dia. stainless steel.
- **BLADE STOP:** 3/8" X 3/8" Rolled stop.
- **FINISH:** Standard Mill.
- **MINIMUM SIZE:** 6" Dia.
- **MAXIMUM SIZE:** 36" Dia.
- **MAXIMUM VELOCITY:** 3500 f.p.m. @ S.P. 5" w.g.
- **MAX. TEMPERATURE:** 500°.

**NOTES:** 1. "D" is the actual dimension, measured inside the flanged frame.

INSIDE DIA. (D)	FLANGE (F)	DEPTH (C)
6" - 7"	1 <sup>1</sup> / <sub>4</sub> " x 1 <sup>1</sup> / <sub>4</sub> " x 1 <sup>1</sup> / <sub>8</sub> "	6" x 14" GA.
8" - 11"	1 <sup>1</sup> / <sub>4</sub> " x 1 <sup>1</sup> / <sub>4</sub> " x 1 <sup>1</sup> / <sub>8</sub> "	8" x 11" GA.
12" - 15"	1 <sup>1</sup> / <sub>2</sub> " x 1 <sup>1</sup> / <sub>2</sub> " x 3 <sup>3</sup> / <sub>16</sub> "	8" x 11" GA.
16" - 24"	1 <sup>3</sup> / <sub>4</sub> " x 1 <sup>3</sup> / <sub>4</sub> " x 3 <sup>3</sup> / <sub>16</sub> "	8" x 11" GA.
25" - 36"	2" x 2" x 3 <sup>3</sup> / <sub>16</sub> "	8" x 11" GA.

**OPTIONS**

- 14 Stainless Steel Axles.
- 87 Stainless Steel Construction.
- 92 Actuators.
- 94 Hand quadrant mounting plate.
- 95 Finishing.

