

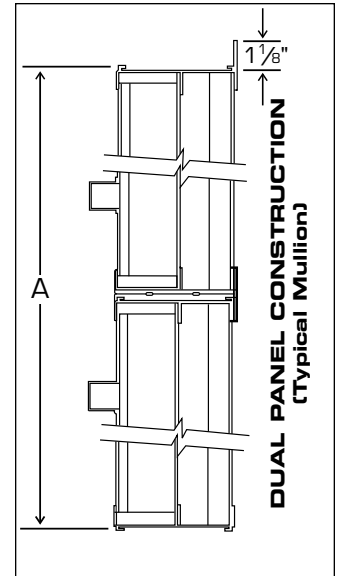

**CERTIFICATION & SUBMITTAL**  
**MODEL 2000 ADJUST-O-VENT COMBINATION DAMPER/LOUVER**  
**WITH CONCEALED MOTOR**  
**Drainable Blade Air Intake**

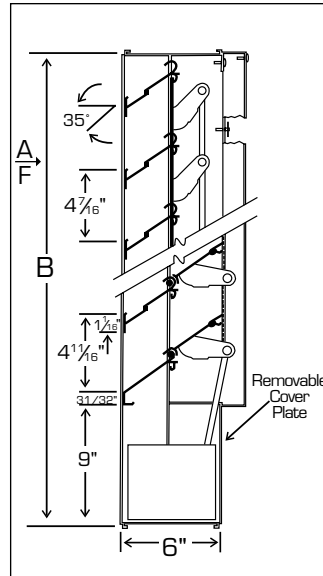

**STANDARD SPECIFICATIONS**

- **FRAME:** .080 6063T5 extruded aluminum.
- **BLADES:** .072 6063T5 extruded aluminum with full length pivoting.
- **BIRDSCREEN:** .051 X 3/4" diamond pattern expanded aluminum.
- **HARDWARE:** Plated steel center brackets; brass pivots; 5/16" dia. plated steel linkage rod.
- **COVER CHANNEL:** .063 aluminum.
- **MOTOR COVER PLATE:** .063 aluminum.
- **BLADE EDGE SEAL:** Vinyl gasketing extending full length of adjustable blades.
- **FINISH:** Standard Mill.
- **MAXIMUM SINGLE SECTION:** 60" x 60", 48" x 72", 24" x 96"
- **MINIMUM SIZE:** 14" x 20"

**OPTIONS**

- CM Concealed Motor.
- 31 Flange.
- 32 Multiple Section.
- 34 Buck Frame.
- 35 Sill Extension.
- 40 Standard Screen in removable frame.
- 42 18 x 16 Mesh aluminum insect screen.
- 43 18 x 16 Mesh bronze insect screen.
- 44 1/2" x 1/2" x 16 gauge S.S. screen.
- 45 1/2" x 1/2" x .063 aluminum screen.
- 89 Sleeve.

**PERFORMANCE DATA MODEL 2000  
EXTRUDED ALUMINUM COMBINATION DAMPER/LOUVER  
Drainable Blade Air Intake**

The ratings shown are based on tests and procedures performed in accordance with AMCA Publication 511 and comply with the requirements of the AMCA Certified Ratings Program. The AMCA Certified Ratings Seal applies to air performance ratings and water penetration ratings.

**FREE AREA CHART**

**A - WIDTH (In Inches)**

B - HEIGHT (In Inches)	A - WIDTH (In Inches)												
	12	16	20	24	28	32	36	40	44	48	52	56	60
12	.17	.24	.31	.38	.46	.53	.60	.68	.75	.82	.89	.97	1.04
16	.33	.48	.62	.77	.91	1.06	1.21	1.35	1.50	1.64	1.79	1.94	2.08
20	.33	.48	.62	.77	.91	1.06	1.21	1.35	1.50	1.64	1.79	1.94	2.08
24	.50	.72	.93	1.15	1.37	1.59	1.81	2.03	2.25	2.47	2.68	2.90	3.12
28	.66	.95	1.25	1.54	1.83	2.12	2.41	2.70	3.00	3.29	3.58	3.87	4.16
32	.83	1.19	1.56	1.92	2.29	2.65	3.02	3.38	3.75	4.11	4.47	4.84	5.20
36	.99	1.43	1.87	2.31	2.74	3.18	3.62	4.06	4.49	4.93	5.37	5.81	6.24
40	1.16	1.67	2.18	2.69	3.20	3.71	4.22	4.73	5.24	5.75	6.28	6.77	7.28
44	1.33	1.91	2.49	3.08	3.66	4.24	4.83	5.41	5.99	6.58	7.16	7.74	8.33
48	1.49	2.15	2.80	3.46	4.12	4.77	5.43	6.09	6.74	7.40	8.05	8.71	9.37
52	1.66	2.39	3.12	3.84	4.57	5.30	6.03	6.76	7.49	8.22	8.95	9.68	10.41
56	1.82	2.62	3.43	4.23	5.03	5.83	6.64	7.44	8.24	9.04	9.84	10.65	11.45
60	1.82	2.62	3.43	4.23	5.03	5.83	6.64	7.44	8.24	9.04	9.84	10.65	11.45
64	1.99	2.86	3.74	4.61	5.49	6.36	7.24	8.11	8.99	9.86	10.74	11.61	12.49
68	2.15	3.10	4.05	5.00	5.95	6.89	7.84	8.79	9.74	10.69	11.63	12.58	13.53
72	2.32	3.34	4.36	5.38	6.40	7.42	8.44	9.47	10.49	11.51	12.53	13.55	14.57
76	2.49	3.58	4.67	5.77	6.86	7.95	9.05	10.14	11.24	12.33	13.42	14.52	15.61
80	2.65	3.82	4.98	6.15	7.32	8.48	9.65	10.82	11.98	13.15	14.32	15.48	16.65
84	2.82	4.06	5.30	6.54	7.78	9.01	10.25	11.49	12.73	13.97	15.21	16.45	17.69
88	2.98	4.30	5.61	6.92	8.23	9.55	10.86	12.17	13.48	14.80	16.11	17.42	18.73
92	3.15	4.53	5.92	7.30	8.69	10.08	11.46	12.85	14.23	15.62	17.00	18.39	19.77
96	3.31	4.77	6.23	7.69	9.15	10.61	12.06	13.52	14.98	16.44	17.90	19.36	20.81

**FREE AREA (Sq. Ft.)**

**AIR PERFORMANCE TEST**

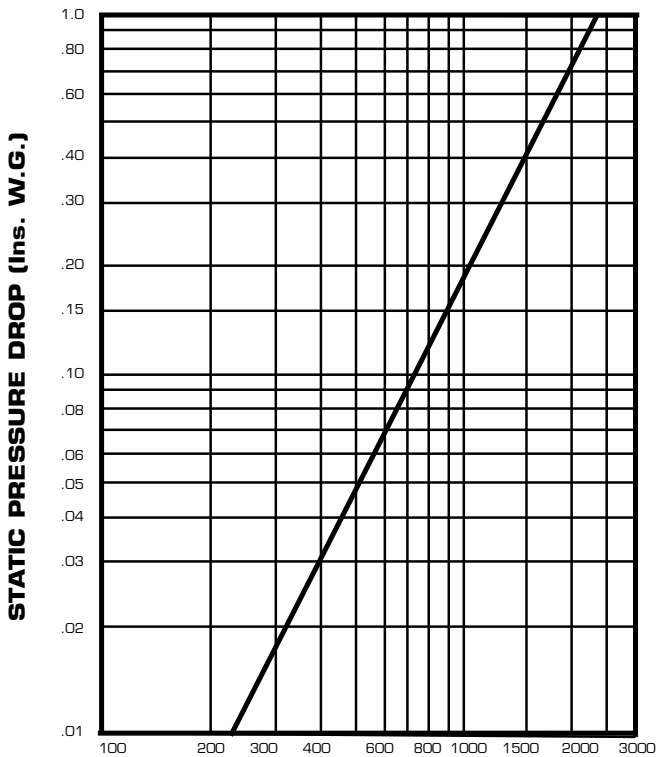

**FREE AREA VELOCITY F.P.M.**

**WATER PENETRATION CHART**

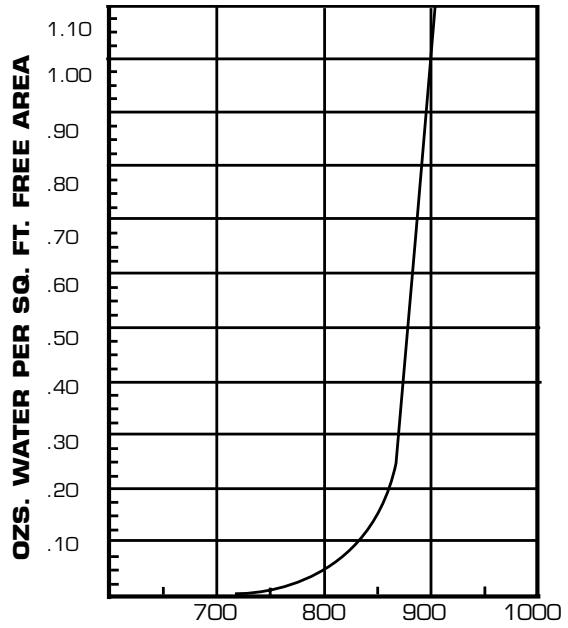

**FREE AREA VELOCITY F.P.M.**

It is possible for moisture to penetrate louvers under adverse atmospheric conditions. For critical applications, drained ductwork or other means of drainage is recommended.

**TEST UNIT SIZE 48" X 48" (15 Min. Duration)**

Data shown includes the effect of .051 x 3/4" diamond pattern aluminum birdscreen. Graphs are corrected to standard air density .075 lb. per cubic foot.

**RECOMMENDED MAXIMUM INTAKE FREE AREA VELOCITY 750 F.P.M.**