

RAIN HOODS - Models: RH-1, RH-2, RH-3, RH-4

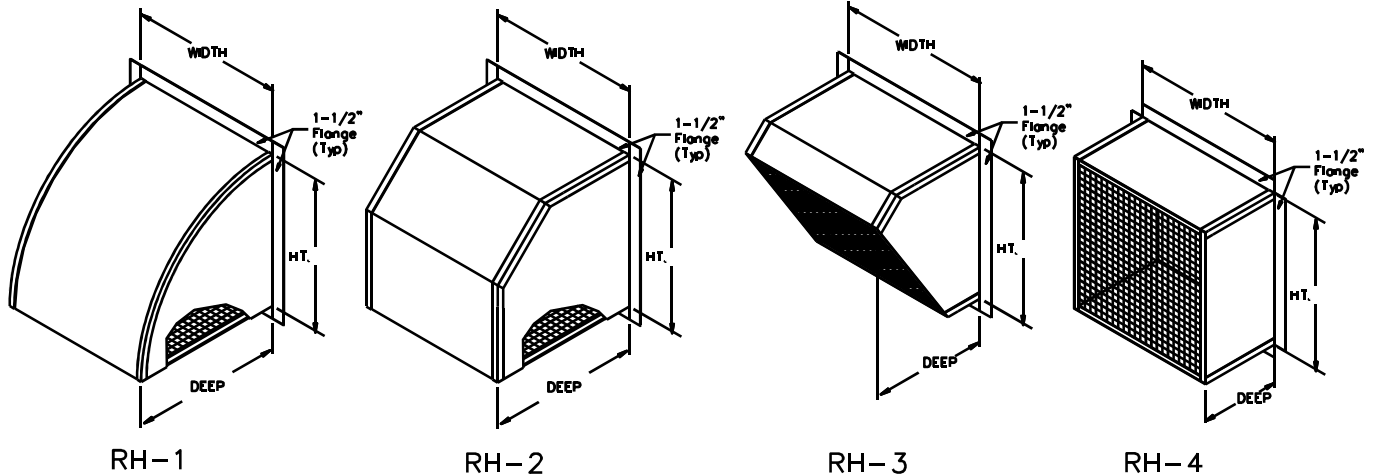

STANDARD CONSTRUCTION

- MATERIAL:** 18 gauge galvanized steel
- ASSEMBLY:** Stitch welded construction
- SCREEN:** 1/2" mesh x 19 ga. galvanized steel
- MAXIMUM SIZE:** Unlimited with mullion, structural bracing as required supplied by others.
- MAXIMUM FACTORY ASSEMBLY SIZE:** 120" x 60" X 60"
- MINIMUM SIZE:** 12" x 12" x 12"
- FINISH:** Mill

Note:
 Width x Height are opening dimensions. Unless otherwise specified, hoods are made 1/4" undersize.

OPTIONAL CONSTRUCTION

- MATERIAL:** Aluminum construction or Stainless steel Available in heavier gauge construction
- ASSEMBLY:** Continuous weld or mechanical fasteners
- BIRDSCREEN:** Standard screen in frame, 18 x 16 mesh aluminum insect screen in frame, 18 x 16 mesh bronze insect screen in frame, 1/2" x 1/2" 16 ga. SS screen, 1/2" x 1/2" x .063" aluminum screen in frame.
- FINISH:** Anodize, Kynar, Prime Coat, Powder Coat, Baked Enamel, Baked Epoxy
- MULLION:** Visible

SPECIAL PURPOSE: With Filter Racks, Security Bars, Blank-off Panels (insulated or non-insulated), Sleeved combined with Control Damper.

Project: _____ Location: _____ Arch/Engr: _____ Customer: _____	HOOD SCHEDULE	Qty	Opening (W x H)	Std. Const.(Y/N)	Options