

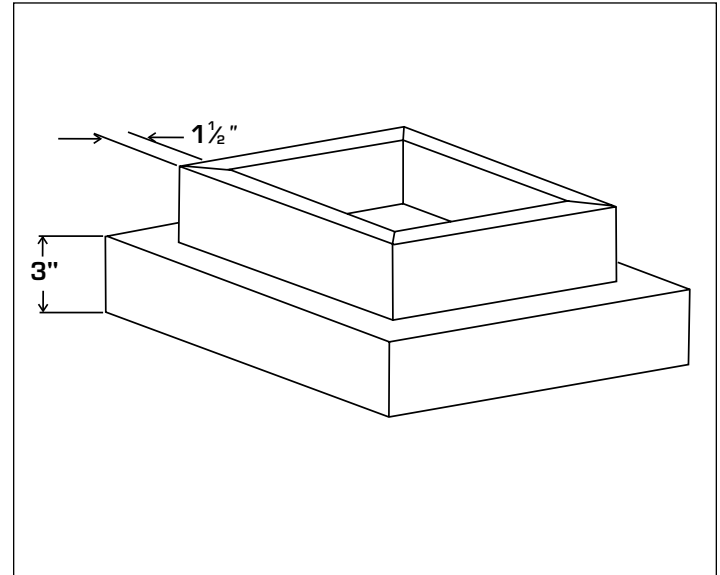

**CERTIFICATION & SUBMITTAL  
MODEL 8600 CURB ADAPTER  
(REDUCER)**

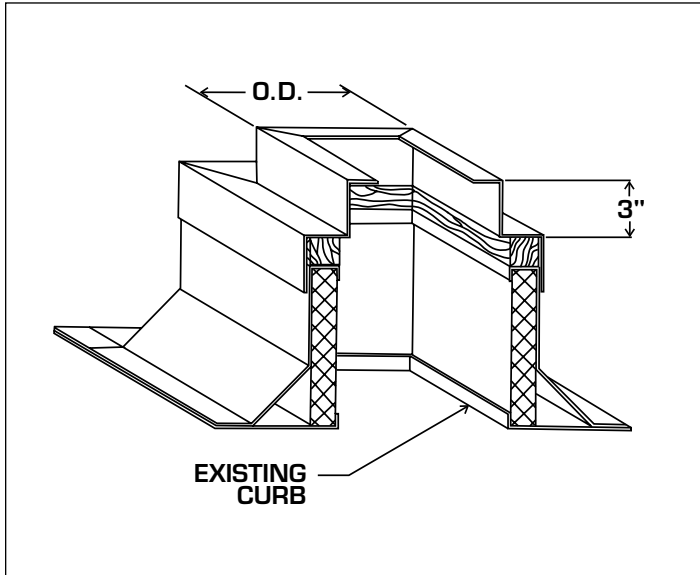

**STANDARD SPECIFICATIONS**

- **SHELL:** 18 ga. galvanized press formed steel with continuous welds on shell seams.
- **WOOD NAILER:** None.

**OPTIONS**

- 53 Treated wood nailer
- 81 16 ga. construction
- 82 14 ga. construction
- 86 Aluminum construction
- WN Wood nailer, factory installed.

**NOTES**

1. When ordering, please specify outside dimensions of existing curbs.

