

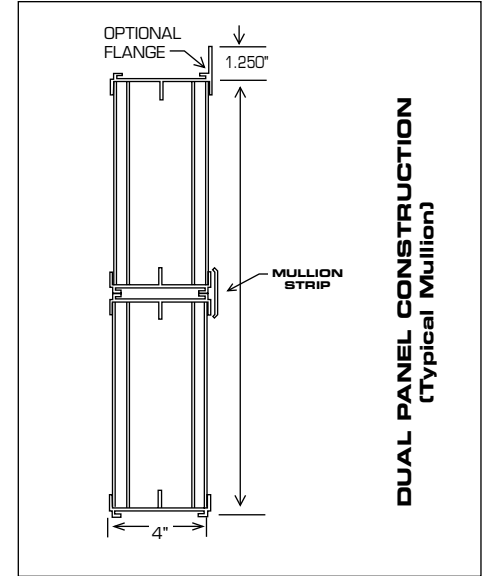

**CERTIFICATION & SUBMITTAL
MODEL 2760 EXTRUDED ALUMINUM AREST-O-VENT
4" Deep Dual Drainable Blade @ 40°**

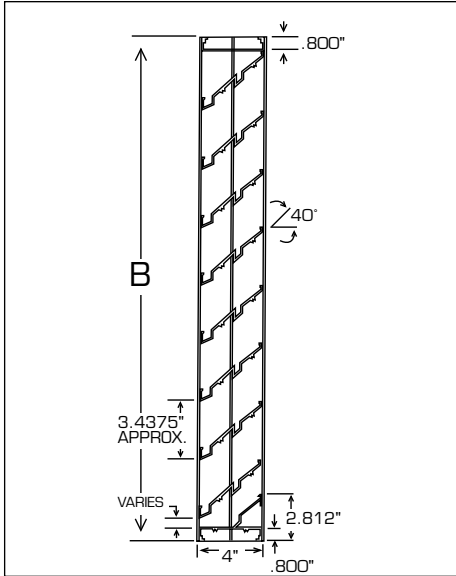

STANDARD SPECIFICATIONS

- **FRAME:** .081 6063T5 extruded aluminum.
- **BLADES:** .081 6063T5 extruded aluminum.
- **BIRDSCREEN:** .051 X 3/4" diamond pattern expanded aluminum.
- **FINISH:** Standard Mill.
- **MAXIMUM SINGLE SECTION:** 72" x 96"
- **MINIMUM SIZE:** 12" x 12"
- **NOTE:** A & B are opening dimensions. Unless otherwise specified, louvers are made 1/4" undersize.

OPTIONS

- 31 Flange.
- 32 Multiple Section.
- 34 Buck Frame (requires flanged louver).
- 35 Sill Extension.
- 40 Standard Screen in removable frame.
- 42 18 x 16 Mesh aluminum insect screen.
- 43 18 x 16 Mesh bronze insect screen.
- 44 1/2" x 1/2" x 16 gauge S.S. screen.
- 45 1/2" x 1/2" x .063 aluminum screen.
- 89 Sleeve.





PERFORMANCE DATA MODEL 2760 EXTRUDED ALUMINUM AREST-O-VENT 4" Deep Drainable Blade @ 40°

Vent Products certifies that the Model 2760 Louver shown herein is licensed to bear the AMCA Seal. The ratings shown are based on tests and procedures performed in accordance with AMCA Publication 511 and comply with the requirements of the AMCA Certified Ratings Program. The AMCA Certified Ratings Seal applies to air performance ratings and water penetration ratings.

		A - WIDTH (In Inches)															
		12	16	20	24	28	32	36	40	44	48	52	56	60	64	68	72
B - HEIGHT (In Inches)	12	.28	.39	.50	.61	.72	.83	.94	1.06	1.17	1.28	1.39	1.50	1.61	1.72	1.84	1.95
	16	.44	.62	.80	.98	1.16	1.34	1.52	1.70	1.88	2.06	2.24	2.41	2.59	2.77	2.95	3.13
	20	.62	.88	1.13	1.38	1.63	1.88	2.14	2.39	2.64	2.89	3.14	3.40	3.65	3.90	4.15	4.41
	24	.80	1.13	1.45	1.78	2.10	2.43	2.75	3.08	3.40	3.73	4.05	4.38	4.70	5.03	5.35	5.68
	28	.98	1.38	1.78	2.18	2.58	2.97	3.37	3.77	4.17	4.57	4.96	5.36	5.76	6.16	6.56	6.95
	32	1.12	1.58	2.03	2.48	2.94	3.39	3.84	4.30	4.75	5.20	5.66	6.11	6.56	7.02	7.47	7.92
	36	1.25	1.76	2.26	2.77	3.27	3.78	4.28	4.79	5.30	5.80	6.31	6.81	7.32	7.83	8.33	8.83
	40	1.47	2.07	2.67	3.26	3.86	4.45	5.05	5.65	6.24	6.84	7.43	8.03	8.62	9.22	9.82	10.41
	44	1.61	2.36	2.92	3.57	4.22	4.87	5.52	6.17	6.82	7.47	8.13	8.78	9.43	10.08	10.73	11.38
	48	1.79	2.52	3.24	3.97	4.69	5.41	6.14	6.86	7.59	8.31	9.04	9.76	10.48	11.21	11.93	12.66
	52	1.97	2.77	3.57	4.36	5.16	5.96	6.76	7.55	8.35	9.15	9.95	10.74	11.54	12.34	13.13	13.93
	56	2.06	2.89	3.72	4.55	5.39	6.22	7.05	7.88	8.71	9.55	10.38	11.21	12.04	12.87	13.71	14.54
	60	2.31	3.24	4.17	5.11	6.04	6.97	7.90	8.84	9.77	10.70	11.63	12.57	13.50	14.43	15.37	16.30
	64	2.49	3.50	4.51	5.51	6.52	7.53	8.54	9.54	10.55	11.56	12.57	13.57	14.58	15.59	16.60	17.60
	68	2.60	3.65	4.70	5.75	6.80	7.85	8.90	9.96	11.01	12.06	13.11	14.16	15.21	16.26	17.31	18.36
	72	2.78	2.90	5.03	6.15	7.28	8.40	9.52	10.65	11.77	12.89	14.02	15.14	16.26	17.39	18.51	19.64
76	2.96	4.16	5.35	6.55	7.75	8.94	10.14	11.34	12.53	13.73	14.93	16.12	17.32	18.52	19.71	20.91	
80	3.14	4.41	5.68	6.95	8.22	9.49	10.76	12.03	13.30	14.57	15.84	17.11	18.38	19.64	20.91	22.18	
84	3.33	4.67	6.01	7.36	8.70	10.05	11.39	12.74	14.08	15.42	16.77	18.11	19.46	20.80	22.14	23.49	
88	3.51	4.93	6.35	7.77	9.19	10.61	12.02	13.44	14.86	16.28	17.70	19.12	20.54	21.96	23.37	24.79	
92	3.59	5.04	6.49	7.94	9.39	10.84	12.29	13.74	15.19	16.64	18.09	19.54	20.99	22.44	23.89	25.34	
96	3.77	5.29	6.82	8.34	9.86	11.38	12.91	14.43	15.95	17.48	19.00	20.52	22.04	23.57	25.09	26.61	

FREE AREA (Sq. Ft.)

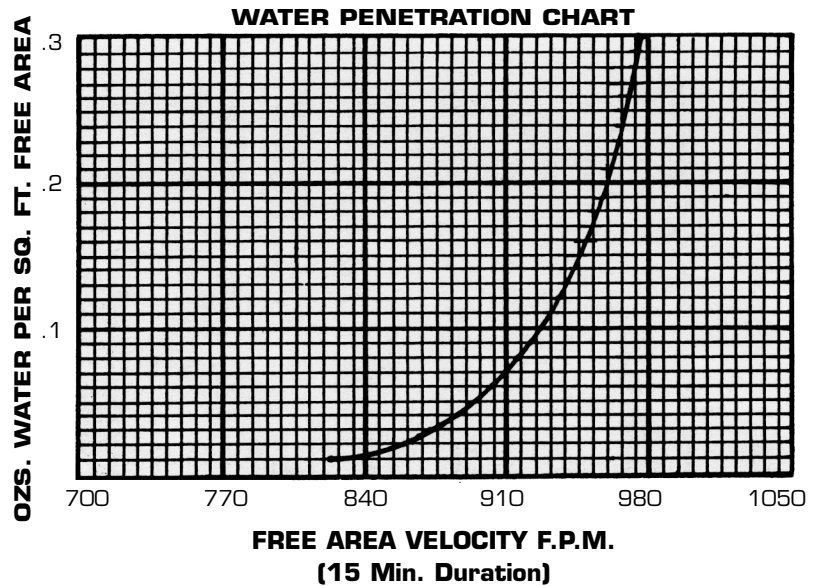
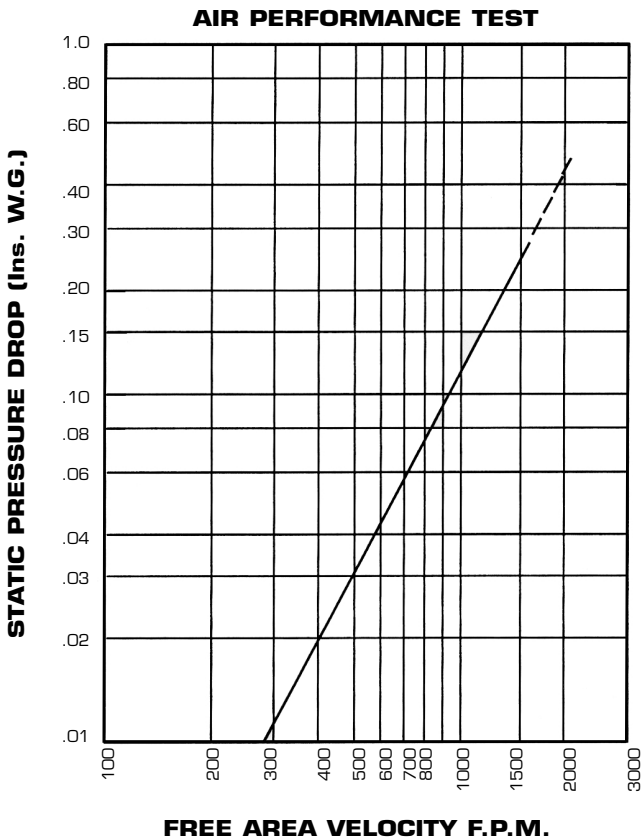

THE BEGINNING OF WATER PENETRATION IS 823 F.P.M.

It is possible for moisture to penetrate louvers under adverse atmospheric conditions. For critical applications, drained ductwork or other means of drainage is recommended.

Air Performance data reflects both intake and exhaust modes.

TEST UNIT SIZE 48" X 48"

Data shown does not include the effect of a birdscreen. Graphs are corrected to standard air density .075 lb. per cubic foot.

RECOMMENDED MAXIMUM INTAKE FREE AREA VELOCITY 800 F.P.M.